

6-13-2006

Low-Distortion Slow Light Using Two Absorption Resonances

Ryan M. Camacho
University of Rochester

Michael V. Pack
University of Rochester

John C. Howell
Chapman University, johhowell@chapman.edu

Follow this and additional works at: https://digitalcommons.chapman.edu/scs_articles



Part of the [Optics Commons](#)

Recommended Citation

R. M. Camacho, M. V. Pack, and J. C. Howell, *Low-Distortion Slow Light Using Two Absorption Resonances*, *Phys. Rev. A* 73(6), 063812. <https://doi.org/10.1103/PhysRevA.73.063812>

This Article is brought to you for free and open access by the Science and Technology Faculty Articles and Research at Chapman University Digital Commons. It has been accepted for inclusion in Mathematics, Physics, and Computer Science Faculty Articles and Research by an authorized administrator of Chapman University Digital Commons. For more information, please contact laughtin@chapman.edu.

Low-Distortion Slow Light Using Two Absorption Resonances

Comments

This article was originally published in *Physical Review A*, volume 73, issue 6, in 2006. <https://doi.org/10.1103/PhysRevA.73.063812>

Copyright

American Physical Society

Low-distortion slow light using two absorption resonances

Ryan M. Camacho, Michael V. Pack, and John C. Howell

Department of Physics and Astronomy, University of Rochester, Rochester, New York 14627, USA

(Received 7 April 2006; published 13 June 2006)

We consider group delay and broadening using two strongly absorbing and widely spaced resonances. We derive relations which show that very large pulse bandwidths coupled with large group delays and small broadening can be achieved. Unlike single resonance systems, the dispersive broadening dominates the absorptive broadening which leads to a dramatic increase in the possible group delay. We show that the double resonance systems are excellent candidates for realizing all-optical delay lines. We report on an experiment which achieved up to 50 pulse delays with 40% broadening.

DOI: [10.1103/PhysRevA.73.063812](https://doi.org/10.1103/PhysRevA.73.063812)

PACS number(s): 42.50.Dv, 03.67.-a

A variety of applications in telecommunications and quantum information has been driving recent interest in slow group velocities of light pulses. Among these applications are continuously tunable delay lines, all-optical buffers [1], optical pattern correlation, ultrastrong cross-phase modulation [2], low light level nonlinear optics [3–5], and numerous others. The means for obtaining ultraslow group velocities have usually involved a Lorentzian transparency or gain resonance: Electromagnetically induced transparency [6–10], coherent population oscillations [11–13], stimulated Brillouin scattering [14–16], stimulated Raman scattering [17,18], etc.

In this paper, we discuss delaying pulses whose center frequency lies between two strongly absorbing resonances. Many researchers have considered using gain doublets in the context of pulse advancement [19–23], and Macke and Segard [22] discussed pulse advancements for absorptive doublets. Grischkowsky [24] measured the delay of a pulse between two Zeeman-shifted absorbing resonances, and Tanaka *et al.* [25] performed initial measurements of the delay of a pulse between two atomic hyperfine resonances. This work considers both delay and broadening with an emphasis on the suitability of the delay and broadening characteristics for practical applications.

In the context of optical delay lines, several criteria must be satisfied for slow light to be useful. First, the slowed light pulses must meet system bandwidth specifications. Second, the delay-bandwidth product must be much larger than unity. Third, the delay reconfiguration rate should be faster than the inverse pulse propagation time through the medium. Fourth, pulse absorption must be kept to a minimum. Fifth, the pulse broadening should also be minimal. The exact requirements for practical optical buffers are application dependent. A typical system operating at 10 Gbits/sec, with return-to-zero coding and a 50% duty cycle might require a 7.5 GHz signal bandwidth, a delay bandwidth product of 1000, a reconfiguration rate in excess of 7.5 MHz with less than 90% absorption, and pulse broadening of less than 2.

Despite widespread interest in large pulse delays, simultaneously satisfying all five criteria for most applications has proven difficult. In this paper, we show that double Lorentzian systems manage four of these criteria well: Large bandwidth, large delay bandwidth product, minimal absorption, and minimal dispersion. Although we have not realized fast reconfiguration rates, there are a number of proposals which

suggest that fast reconfiguration rates using double Lorentzians may be possible. In single and double Lorentzian systems, there exists a tradeoff between large delay-bandwidth products and pulse broadening. We show that double Lorentzians, in contrast to single Lorentzians, have interesting properties which help minimize this tradeoff while preserving all other criteria.

Consider two absorbing Lorentzian lines of equal width, separated by a spectral distance much larger than their widths. Following the single Lorentzian formalism of Ref. [26], the susceptibility of the double Lorentzian is given by

$$\chi = \beta \left(\frac{1}{\omega_1 - \omega - i\gamma} + \frac{1}{\omega_2 - \omega - i\gamma} \right), \quad (1)$$

where β is the strength of the susceptibility and 2γ is the full width at half maximum (FWHM). Making the change of variables $\omega = (\omega_1 + \omega_2)/2 + \delta$ and $\omega_0 = (\omega_2 - \omega_1)/2$, and assuming the far detuned limit (i.e., $\omega_0 \gg \gamma$), we may neglect the half width term in the denominator. We further assume the pulse frequencies to lie within the range $|\delta| \ll \omega_0$, the pulse bandwidth to be larger than the Lorentzian half width, γ , and $\chi \ll 1$. The real and imaginary parts of the refractive index $n = n' + in'' \approx 1 + \chi/2$ may then be written as

$$n' \approx 1 + \frac{\beta}{2} \left(\frac{1}{\delta + \omega_0} + \frac{1}{\delta - \omega_0} \right), \approx 1 + \frac{\beta}{\omega_0^2} \delta + \frac{\beta}{\omega_0^4} \delta^3, \quad (2)$$

and

$$n'' \approx \frac{\beta\gamma}{2} \left(\frac{1}{(\delta + \omega_0)^2} + \frac{1}{(\delta - \omega_0)^2} \right), \approx \frac{\beta\gamma}{\omega_0^2} + 3 \frac{\beta\gamma}{\omega_0^4} \delta^2, \quad (3)$$

where the power series are expanded about $\delta=0$.

The optical depth $\alpha L = 2\omega L n''/c$ (here L is the interaction length and α is the intensity coefficient) at the midpoint between the Lorentzians is found to be $\alpha_m L = 2\omega L \beta \gamma / c \omega_0^2$, which implies $\partial n' / \partial \delta|_{\delta=0} = c \alpha_m / 2 \gamma \omega$. The group velocity is then given by

$$v_g \approx \frac{c}{\omega (\partial n' / \partial \delta)} = \frac{2\gamma}{\alpha_m}, \quad (4)$$

and the group delay is given by

$$t_g = \frac{L}{v_g} \approx \frac{\alpha_m L}{2\gamma}. \quad (5)$$

The dispersive and absorptive broadenings in the small-pulse-bandwidth limit (i.e., pulse bandwidth is much smaller than the spectral distance between Lorentzians) are dominated by the second terms in the power series expansions of the real and imaginary parts, respectively. The absorptive broadening is due to the spectrally dependent absorption in the wings of the pulse spectrum. In the small-pulse-bandwidth limit, the absorption can be approximated by a Gaussian-shaped spectral filter plus a constant absorption:

$$S(\delta) = \exp[-\alpha(\delta)L] \approx \exp[-\alpha_m L - 3\delta^2 \alpha_m L / \omega_0^2]. \quad (6)$$

When the input pulse is a bandwidth-limited Gaussian, we find that in the frequency domain the output pulse is the product of the spectral filter and the input pulse spectrum $A_{\text{in}}(\delta)$:

$$A_{\text{out}}(\delta) = A_{\text{in}}(\delta)S(\delta) \propto \exp\left[-\alpha_m L - \delta^2\left(T_0^2 \ln 2 - \frac{3\alpha_m L}{\omega_0^2}\right)\right],$$

where T_0 is the input half width at half maximum of the pulse. Thus, accounting for only absorptive broadening, the temporal half width after traversing the medium is

$$T_a = \sqrt{T_0^2 + \frac{3\alpha_m L}{\omega_0^2 \ln 2}}. \quad (7)$$

The temporal broadening due to dispersion is approximated by taking the difference in group delay for a pulse centered at $\delta=0$ and a pulse centered at $1/T_0$. The temporal half width due to dispersion is

$$T_d = T_0 + \frac{3\alpha_m L}{4 \ln(2) \gamma \omega_0^2 T_0^2}. \quad (8)$$

The total pulse broadening is found by replacing T_0 in Eq. (8) with T_a from Eq. (7):

$$T_{\text{tot}} = \sqrt{T_0^2 + \frac{3\alpha_m L}{\omega_0^2 \ln 2}} + \frac{3\alpha_m L}{4\gamma\omega_0^2 \ln 2 (T_0^2 + (3\alpha_m L / \omega_0^2 \ln 2))}. \quad (9)$$

We focus on the case where $\omega_0 \gg 1/T_0 \gg \gamma$ and $T_a/T_0 \leq 2$, corresponding to our experimental parameters. For this case, the dispersive broadening dominates (i.e., the second term on the right-hand side of Eq. (8) contributes most to the broadening). However, the quadratic absorption is still significant since it reduces the effects of dispersive broadening by most strongly absorbing those frequencies which experience the largest dispersion (i.e., frequency wings of the pulse). For the parameters considered in this paper, pulse broadening is less with both absorptive and dispersive broadening included, than for dispersive broadening alone. In single Lorentzian systems, absorption is the dominant broadening mechanism and this relationship between broadening mechanisms is not significant.

Although in hot Rb vapor the resonances experience strong inhomogeneous Doppler broadening; in the far-wing limit, the Rb resonances are essentially Lorentzian and the double Lorentzian formalism is a very good approximation. The Rb⁸⁵ D₂ hyperfine resonances are separated by approximately 3 GHz, so the Gaussian Doppler broadening of ap-

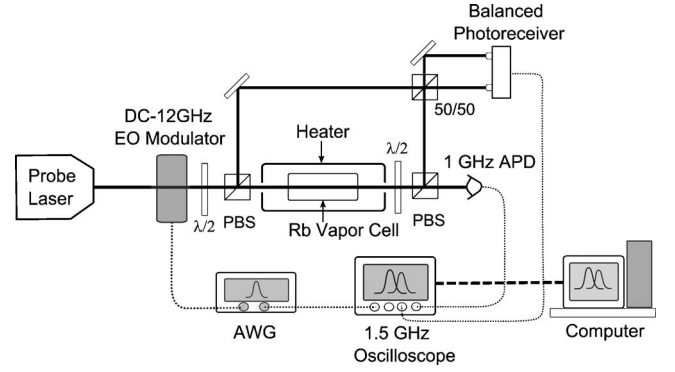

FIG. 1. Experimental schematic. A probe laser passes through a heated rubidium vapor cell, and is either measuring directly using a fast detector, or after interference on a balanced photoreceiver.

proximately 500 MHz has little effect on the absorptive behavior. Also, collisional broadening was not significant for the temperatures used in this work.

A diagram of the experimental setup is shown in Fig. 1. A narrowband (300 KHz) diode laser at 780 nm generates a beam of light tuned halfway between the Rb⁸⁵ D₂ hyperfine resonances, which is fiber coupled into a fast electro-optic modulator (EOM). An arbitrary waveform generator (AWG) drives the EOM, producing light pulses with a duration of approximately 2 ns FWHM. The light pulses then pass through a 10 cm glass cell containing rubidium in natural isotopic abundance. The cell is heated with electronic strip heaters and enclosed in a cylindrical oven with antireflection coated windows. The pulse is then incident upon a 1 GHz avalanche photodiode (APD) and recorded on a 1.5 GHz oscilloscope triggered by the AWG.

A Mach-Zehnder interferometer was also used with a balanced photoreceiver in order to make continuous-wave (cw) measurements of the transmission and phase delay as a function of frequency. The difference signal from the balanced photoreceiver provides phase information while transmission data are obtained by blocking one of the photoreceiver photodiodes. The beam splitter preceding the vapor cell is polarizing to allow for easy balancing of the interferometer arms, and the beam splitter immediately following the vapor cell is polarizing to allow switching between the fast APD and cw balanced detection.

Figures 2(a) and 2(b) show absorption and phase spectroscopy scans for the transmission window resulting in a measured 26 ns pulse delay, respectively. The transmission window has a width of approximately 1 GHz, which is a sufficient acceptance bandwidth for the 2 ns pulses used in this experiment. The interference fringes were obtained by sweeping the laser frequency and monitoring the intensity difference at the two output ports of a Mach-Zehnder interferometer (see Fig. 1).

It is straightforward to predict the group delay from the absorption scan or measure it directly using the interference fringes. From the absorption data, we may extract the optical depth and calculate the group delay via Eq. (5), giving approximately 26 ns for absorption data in Fig. 2(a), in good agreement with the measured delay. In contrast, from the interference fringes we may extract the group delay directly:

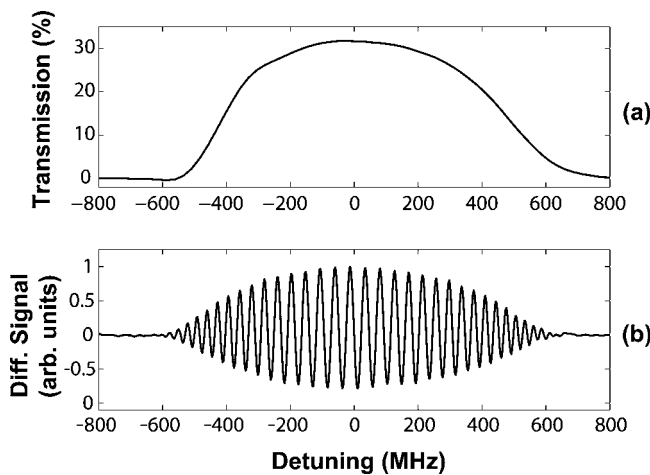

FIG. 2. (a) Probe transmission versus probe detuning and (b) difference signal from the balanced photoreceiver with each fringe corresponding to a 2π phase shift. The height of the fringes is in arbitrary units. Both transmission and phase data were taken with a 10 cm Rb vapor cell at approximately 130 °C (corresponds to a group delay of 26 ns).

$$t_g = \frac{L}{v_g} = \frac{L\omega(\partial n'/\partial\delta)}{c} \approx \frac{\Delta\phi}{\Delta\delta} = \frac{\Delta N}{\Delta f}, \quad (10)$$

where ΔN is the number of fringes in a frequency range Δf . For the resonance shown in Fig. 2(b), there are approximately 25 fringes per GHz, giving a predicted optical delay of $25/1 \text{ GHz} = 25 \text{ ns}$, also in good agreement with measured values. We note that the maximum delay-bandwidth product of a dispersive medium is approximately given by the maximum number of interference fringes that can be obtained within the acceptance bandwidth.

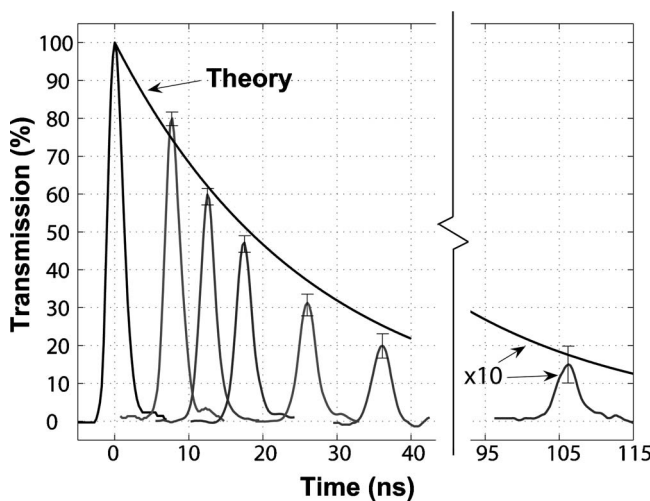

FIG. 3. Pulse delay at various optical depths. On the left, 2.4 ns pulses are passed through a 10 cm vapor cell and the delay is tuned by changing temperature. On the right, a 2.1 ns pulse is passed through four 10 cm cells and delayed 106 ns (50 fractional pulse delays).

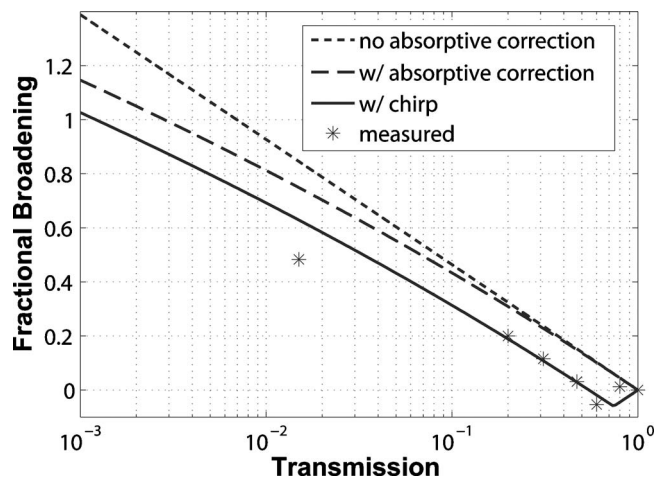

FIG. 4. Fractional pulse broadening versus natural log of transmission. Fractional broadening is defined as the fractional increase pulse duration at FWHM (a value of 0 means no broadening). Due to absorption, the actual broadening is less than that predicted by the dominant dispersive term, even though absorptive broadening is negligible.

Figure 3 shows the probe pulse transmission and delay for various cell temperatures, plotted in units of percent transmission. Using a 2.4 ns long pulse (FWHM) and a single 10 cm vapor cell, and varying the temperature between 90 °C and 140 °C, we were able to tune between 8 ns and 36 ns of delay. We note that several pulse delays are obtainable with greater than $1/e$ peak transmission. In order to achieve 106 ns of delay, with a delay-bandwidth product of 50 and a broadening of approximately 40%, we used a 2.1 ns (FWHM) pulse incident on a series of four 10 cm vapor cells all heated to approximately 130 °C. The theoretical prediction of transmission as a function of group delay [Eq. (5)] is also plotted using the Rb D_2 homogeneous linewidth $2\gamma = 2\pi \times 6.07 \text{ MHz}$ from [27]. The discrepancy between the measured pulse intensities and the theoretical pulse energies can largely be attributed to pulse broadening spreading the pulse energy over a larger time resulting in lower peak intensities.

Figure 4 compares the fractional broadening of the delayed pulses shown in Fig. 3 to the predicted values calculated using Eqs. (7)–(9). Shown in Fig. 4 are the measured broadening values, the predicted total broadening without absorptive corrections, $(T_a + T_d - T_0)/T_0$, the total predicted broadening, $(T_{\text{tot}} - T_0)/T_0$ and the total predicted broadening with a chirplike like correction. As predicted by Eq. (9), the data show that the quadratic absorption decreases the broadening due to dispersion. Also, for small optical depths, the pulse width compresses before broadening, which may be modeled by assuming a small negative chirp on the input pulse. We do not know the origins of the chirp, but we found that by including a small second-order chirp in the theory, we obtained a very good fit to the data.

In conclusion, we have discussed the delay and broadening characteristics for pulses propagating through a double-Lorentzian medium (i.e., a medium with two widely spaced

absorbing Lorentzian resonances). For many slow-light applications, absorptive double Lorentzian systems seem to be better suited than gainlike single Lorentzian systems. Since the spacing between the two Lorentzians can be arbitrarily large, the usable bandwidth may be proportionately large, though practical considerations may limit the separation. Also, in contrast to single Lorentzians, the double Lorentzian line shape is dominated by dispersive broadening and not absorptive broadening, resulting in less pulse distortion for a given delay. While the method of tuning the delay in the

present experiment was slow (increasing the temperature of the vapor cell), there may be ways to achieve fast reconfiguration rates. Some possibilities may be to drive a large number of atoms to saturation with a strong auxiliary beam, or make use of light induced desorption [28] of Rb to optically change the atomic number density.

This work was supported by DARPA Slow Light, the National Science Foundation, and Research Corporation. Research Corporation

-
- [1] R. W. Boyd, D. J. Gauthier, A. L. Gaeta, and A. E. Willner, *Phys. Rev. A* **71**, 023801 (2005).
- [2] H. Schmidt and A. Imamoglu, *Opt. Lett.* **21**, 1936 (1996).
- [3] S. E. Harris and L. V. Hau, *Phys. Rev. Lett.* **82**, 4611 (1999).
- [4] M. D. Lukin and A. Imamoglu, *Phys. Rev. Lett.* **84**, 1419 (2000).
- [5] R. G. Beausoleil, W. J. Munro, and T. P. Spiller, *J. Mod. Opt.* **51**, 1559 (2004).
- [6] A. Kasapi, M. Jain, G. Y. Yin, and S. E. Harris, *Phys. Rev. Lett.* **74**, 2447 (1995).
- [7] C. Liu, Z. Dutton, C. H. Behroozi, and L. V. Hau, *Nature (London)* **409**, 490 (2001).
- [8] M. M. Kash, V. A. Sautenkov, A. S. Zibrov, L. Hollberg, G. R. Welch, M. D. Lukin, Y. Rostovtsev, E. S. Fry, and M. O. Scully, *Phys. Rev. Lett.* **82**, 5229 (1999).
- [9] D. Budker, D. F. Kimball, S. M. Rochester, and V. V. Yashchuk, *Phys. Rev. Lett.* **83**, 1767 (1999).
- [10] L. V. Hau, S. E. Harris, Z. Dutton, and C. Behroozi, *Nature (London)* **397**, 594 (1999).
- [11] M. S. Bigelow, N. N. Lepeshkin, and R. W. Boyd, *Science* **301**, 200 (2003).
- [12] X. Zhao, P. Palinginis, B. Pesala, C. Chang-Hasnain, and P. Hemmer, *Opt. Express* **93**, 7899 (2005).
- [13] P. Palinginis, F. Sedgwick, S. Crankshaw, M. Moewe, and C. J. Chang-Hasnain, *Opt. Express* **13**, 9909 (2005).
- [14] Y. Okawachi, M. S. Bigelow, J. E. Sharping, Z. Zhu, A. Schweinsberg, D. J. Gauthier, R. W. Boyd, and A. L. Gaeta, *Phys. Rev. Lett.* **94**, 153902 (2005).
- [15] M. Gonzalez-Herrez, K.-Y. Song, and L. Thvenaz, *Appl. Phys. Lett.* **87**, 081113 (2005).
- [16] M. Gonzalez-Herrez, K.-Y. Song, and L. Thvenaz, *Opt. Express* **14**, 1400 (2006).
- [17] D. Dahan and G. Eisenstein, *Opt. Express* **13**, 6234 (2005).
- [18] J. E. Sharping, Y. Okawachi, and A. L. Gaeta, *Opt. Express* **13**, 6092 (2005).
- [19] R. Y. Chiao, *Phys. Rev. A* **48**, R34 (1993).
- [20] L. J. Wang, A. Kuzmich, and A. Dogariu, *Nature (London)* **406**, 277 (2000).
- [21] A. Dogariu, A. Kuzmich, and L. J. Wang, *Phys. Rev. A* **63**, 053806 (2001).
- [22] B. Macke and B. Segard, *Eur. Phys. J. D* **23**, 125 (2003).
- [23] G. S. Agarwal and S. Dasgupta, *Phys. Rev. A* **70**, 023802 (2004).
- [24] D. Grischkowsky, *Phys. Rev. A* **7**, 2096 (1973).
- [25] H. Tanaka, H. Niwa, K. Hayami, S. Furue, K. Nakayama, T. Kohmoto, M. Kunitomo, and Y. Fukuda, *Phys. Rev. A* **68**, 053801 (2003).
- [26] R. Boyd and D. J. Gauthier, *Progress in Optics* (Elsevier, New York, 2002), p. 497.
- [27] U. Volz and H. Schmoranzer, *Phys. Scr., T* **65**, 48 (1996).
- [28] E. B. Alexandrov, M. V. Balabas, D. Budker, D. English, D. F. Kimball, C. H. Li, and V. V. Yashchuk, *Phys. Rev. A* **66**, 042903 (2002).